

MULTI¹NE

COMPACT LOADER



11.6 K
11.9 K

ENGLISH



BEST IN CLASS

WE WANT YOUR MULTIONE ARTICULATED COMPACT LOADER TO BE YOUR GO-TO MACHINE ALL DAY LONG.

POWERFULL AND VERSATILE

READY TO USE ANYWHERE

Compact articulated loaders are real workhorses in a lightweight compact format. These powerful and handy multi-purpose machines are wonderfully easy to operate and are suitable for a wide variety of applications.

① JOYSTICK

The multi-function electronic joystick enables easy and precise control of the loader boom and attachments. All controls are here, at your fingertips.



① CRUISE CONTROL

The MultiOne Cruise Control maintains a steady speed as set by the operator. Constant speed will give perfect results on the job site with a variety of attachments.



① DASHBOARD AND CONTROLS

Every component is considered by MultiOne, to maximise comfort and control. The cab layout is designed with attention to ergonomic principles, intuitive location of instruments and controls ensure the ease of use.

① UNBREAKABLE BODY PANELS

The resistance and flexibility of the compound used on the new body cover let the panel absorb shocks, deforms and go back to original shape.

① ENGINE

57 or 75 HP Kohler, compliant with Stage V, emission standards.

① RADIAL PISTON WHEEL MOTOR

The 4 Radial piston heavy duty and high efficiency wheel motors provide power with great control and reliability. Two speed available.

① TELESCOPIC BOOM

Only MultiOne has a double-H telescopic boom design, which gives extreme strength and symmetrical loading. Proven efficiency.



① WIDE CHOICE OF TYRES

Tires selectable according to the application.



① GREAT TRACTION

MultiOne loaders are equipped with four-wheel direct drive hydraulic motors and differential lock (DBS + Torque Divider) which guarantee maximum traction on all terrains. Rubber tracks available as option.

① 360° VISIBILITY

The 360° Operator Visibility is a well known MultiOne plus.

① MULTICONNECTOR + ACI

The Multiconnector lets you plug-in all hydraulic lines at once and drip free. ACI system allows the driver to control the attachments' movements without the need for separate control boxes, cables or additional wiring. The connection to the attachments is plug & play, reliable and easy.

① OVER 170 ATTACHMENTS

MultiOne has a decade-long experience of designing and implementing dedicated attachments. This know-how assures the best attachments for mini loaders are branded MultiOne.



① HIGH SPEED

Multione 11 series is equipped with a Double Speed Transmission system. The 4 Radial piston wheel motors provide a speed up to 35 km/h.



① LIFTING CAPACITY

The MultiOne loader can lift and handle heavy loads. You'll get excellent lifting capacity in a compact machine on any jobsite.

① COMFORT CAB

Heated seat, heating system and full glass cabin with weatherproof blue tinted glass, large door, side opening window. It's the optimal solution for driver protection from cold, wet and wind.



① SELF-LEVELLING BOOM

This system is installed on the machine boom and keeps the load level, without the need to continuously correct the position with the joystick.



① ONE DRIVE

OneDrive is a brand new transmission system. Its design dramatically reduces the power loss (-30%) by internal resistance of oil flow.



GREAT PERFORMANCES



① BEST IN CLASS WEIGHT TO LIFT RATIO
MultiOne provides superior lifting capacity and excellent front visibility. Thanks to the auxiliary rearweights it's possible to lift up to 2,6 tons of load.

① BOOM LIFTING HEIGHT
Only MultiOne has a double-H pattern, telescopic and self-levelling boom, which gives extreme strength and symmetrical loading. This provides superior lifting capacity and excellent front visibility. The telescopic boom has a significant extension in length, which grants greater horizontal outreach and lifting height up to 3,7 m.



① LOW GROUND IMPACT
The articulated chassis and advanced driving system improve traction and flotation with a light footprint on sandy or wet ground conditions. Precise and smooth steering controls grant high manoeuvrability in tight spaces. Low tyre wear and low ground impact are the result of DBS and Torque Divider.



① SPEED AND MANEUVERABILITY
The 4 Radial piston wheel motors provide high speed and pushing force. Double transmission speed and full lock 4WD are available at the flick of a switch. MultiOne machines feature a sturdy articulated chassis that improves balance and overall stability with a high constant payload in all environments. MultiOne's compact size offers great manoeuvrability in tight spaces.

① LARGE OIL FLOW OUTPUT
The MultiOne advanced hydraulic circuit delivers power to the attachment, boom and transmission simultaneously and with independent control. Two gear pump and the HI-FLOW system assures a large flow hydraulic output to the attachments.



ONE DRIVE

TRACTION ON ALL TERRAIN



ONE DRIVE

The MultiOne OneDrive is a brand new transmission system made by a single block valve directly coupled to the HST pump. OneDrive increases the transmission performance while reducing heat and fuel consumption. The system provides a smooth but rock solid control on the foot pedals and reduces the fatigue during long operation hours. It allows a wider speed range, and the improved efficiency allows to reach very high travel speed and increases the components lifetime. OneDrive performance output is higher than standard circuit.



CRUISE CONTROL

The cruise control is a great feature of OneDrive, as all attachments that require constant speed are now very easy to run: just set the working speed and the OneDrive will do the job for you. Constant speed will give perfect results on the job site with a variety of attachments. It gives its best when used with lawn mowers, flail mowers, power harrow, stone burier, rotary tiller, power rake and other ground care and soil preparation attachments. It synchronizes the attachment working speed with loader and engine speed. Use it and you'll appreciate it. The Cruise Control is activated by the joystick.

DYNAMIC BLOCK SYSTEM AND TORQUE DIVIDER

MultiOne features the DBS, so the machine does not damage the surfaces while operating and, when needed, the Torque Divider gives a real time 4WD for maximum traction on all surfaces. All controls are on the joystick. Configure the trigger switch according to your needs with a touch of the switch on main panel.

TRACK DRIVE OPTION

Track drive grant maximum stability & traction, with minimal ground damage and low ground bearing pressure.

The large contact area under the tracks reduces pressure, minimises ground damage and avoids sinking into soft soil & creating ruts.

The main features of the track drive are:

- Great traction on any terrain;
- Smooth riding;
- 10° Swing floatation;
- Reduced ground impact;
- Chevron pattern: enhanced grip;
- 8 wheels undercarriage;
- HD construction grade rubber tracks.



COMFORT

① COCKPIT AND DASHBOARD

MultiOne doesn't see comfort as a luxury. It's essential to the productivity. That's why every MultiOne loader is designed with the operator's experience in mind. Visibility, cab space, ease of control, air flow and ergonomics add up to focused work and satisfied operators.



① Multifunction Joystick

The Multifunction Joystick enables easy and precise control of the loader boom and attachments.



① Control panel

LCD graphic display with service intervals alerts. Handy switches to operate auxiliary functions.



① Seat

Ergonomic heated full adjustable suspension seat with armrests and seat belt.



CABIN



Stay comfortable in cold and wet weather with the optional full glass cabin with weatherproof blue tinted glass. The side window opens to provide fresh airflow across the operator, helping to provide more comfort. Strategically placed, louvered vents quickly defrost windows and direct heat to operator, providing excellent all-season versatility for winter months. The heated seat helps to keep your body warm and comfortable while working on frigid days.

Air conditioning system with electronic temperature control is available for warm climates.



① Heating System

New heating system even more efficient with 9 adjustable air vents.



① Side Window

The side window opens to ensure excellent ventilation of the cabin.



① A/C System

Air conditioning system with adjustable fan speed and electronic temperature control.



MULTIFUNCTIONAL

With over 170 different attachments that can be changed in seconds, MultiOne ensure that a solution is at hand for any task, no matter how big, small or demanding. Expensive labour cost is dramatically reduced by mechanising a vast array of jobs. Hydraulic quick coupling system standard on all loaders provide seamless and effortless replacement of all attachments ensuring the ultimate flexible solution. The new ACI system (Attachment Control Interface) allows the operator to control all the attachment functions only with the multifunction joystick, for a more efficient work experience.



① Coupling plate

The coupling plate allows you to connect the attachments quickly and safely. It is also available with hydraulic control.



① Multiconnector

The Multiconnector lets you plug-in all attachment hydraulic lines at once and drip free.



① ACI System

ACI system allows to control the attachments' movements with the buttons on joystick without the need for separate controls.



MULTI ONE



EASY MAINTENANCE

① EASY ACCESS TO FILTERS

When you rely on your equipment to complete your job, serviceability has to be easy – and it can't take up too much of your time. MultiOne always keeps easy serviceability in mind, ensuring that components are easy to reach and daily maintenance is quick to complete.

The easy-to-read, LCD graphic display provides operating information and machine warnings.

The high-capacity filter with visual indicator delivers clean airflow to your engine and excellent contaminant-holding capacity for long life and maximum component protection.



EASY TO TRANSPORT

① COMPACT AND LIGHT

MultiOne's compact size offers great maneuverability in narrow spaces. From a small indoor working area to an open field, MultiOne can reach places other machines can't. Despite its robust construction, the lightweight loader can be easily transported on a regular car trailer.

UNBREAKABLE BODY PANELS

The MultiOne body panels using a special compound that make them indestructibles.

The panels absorb shocks, deform and go back to original shape.

Other features of these panels are:

- UV protection.
- Wide temperature range resistance.
- Modern matt finishing surface.

All this guarantees a long life to the panels.



OPTIONS

Simply give your machine a personal touch or choose a function that you need. A wide selection of options to customize your compact articulated loader!

① AVAILABLE OPTIONS

- A/C system with heating
- Attachment coupling plate for rear mounting
- Automatic locking plate
- Auxiliary double front hydraulic outlets
- Auxiliary single rear hydraulic outlet
- Auxiliary double rear hydraulic outlet
- Auxiliary Working lights
- Backup warning beeper
- Beacon light
- Biodegradable oil
- Driver area cover
- Engine block heater
- Floating boom system
- Fully enclosed cab
- GPS kit
- Heating system
- Left protection bar
- Mirrors
- Rear 12 VDC outlet
- Rear bull bar
- Rear weights
- Rubber tracks kit
- Side weights
- Smart cabin
- Snow Chains
- Tie down bracket
- Trailer coupling
- Turf or skid tyres
- Warning & safety lights for road travel
- Wheel spacer



11.6 K



- PLUS**
- High power and torque engine
 - High speed
 - High lifting height and capacity
 - Multifunction Joystick + ACI
 - One Drive (DBS+Cruise Control+Torque Divider)
 - Self levelling telescopic boom
 - High comfort:
 - Heated seat as standard
 - Smart cabin available
 - Full glass cabin available
 - Heating system available
 - A/C system available



High Power Articulated Mini Loader.

MultiOne 11.6 K has all the new astonishing MultiOne features like OneDrive, Cruise Control, ACI and Unbreakable Body Panels, together with a top class lifting height and lifting capacity.

The MultiOne 11.6 K has been designed to be the first articulated compact loader to reach a lifting height of 3,7 m. This goal has been reached thanks to a new telescopic boom. The new boom and new rear weights allow the 11.6 k to show a lifting capacity up to 2,5 ton.



<p>MAX LIFTING CAPACITY</p> <p>2540 kg</p>	<p>ENGINE POWER</p> <p>57 hp</p>	<p>SPEED</p> <p>30 km/h</p>	<p>FLOW RATE</p> <p>84 l/min</p>	<p>LIFT HEIGHT</p> <p>3,7 m</p>	<p>WEIGHT</p> <p>2320 kg</p>	<p>ACI ATTACHMENT CONTROL INTERFACE</p> <p>CRUISE CONTROL</p>	
--	----------------------------------	-----------------------------	----------------------------------	---------------------------------	------------------------------	---	--

HIGHLIGHTS

- **11.6 K STAGE V** - Kohler KDI1903TCR, 57 hp, 3 cyl., 1861 cc, Turbo common rail diesel engine with DPF, water cooled with electric start
- Stage V compliant engine
- One Drive (DBS+Torque divider+Cruise Control) available as option
- ETC - Electronic Throttle Control
- Unbreakable Body Panels
- Hydraulic oil cooler
- Two speed
- Hydraulically pilot operated variable displacement drive pump
- Hydraulic multiconnector
- Self-levelling double-H telescopic boom
- Hi-Flow system with 2 gear pumps
- ACI with Multi-functions joystick (22 functions)
- ROPS-FOPS Level I
- LCD graphic display with programmed service
- 4WD hydrostatic Direct Drive motors, proportional servo control
- Radial piston high efficiency and heavy duty wheel motors
- 2 front working light
- Ergonomic full adjustable suspension heated seat with armrests and seat belt
- Self-locking multi-disk parking brake
- 380/55-17 wheels

ENGINE STAGE V

The 11.6 K model is equipped with Stage V compliant engines. The Engine is a Kohler 57 HP with DPF that provide a high torque at low rpm (225 Nm @ 1500 rpm).

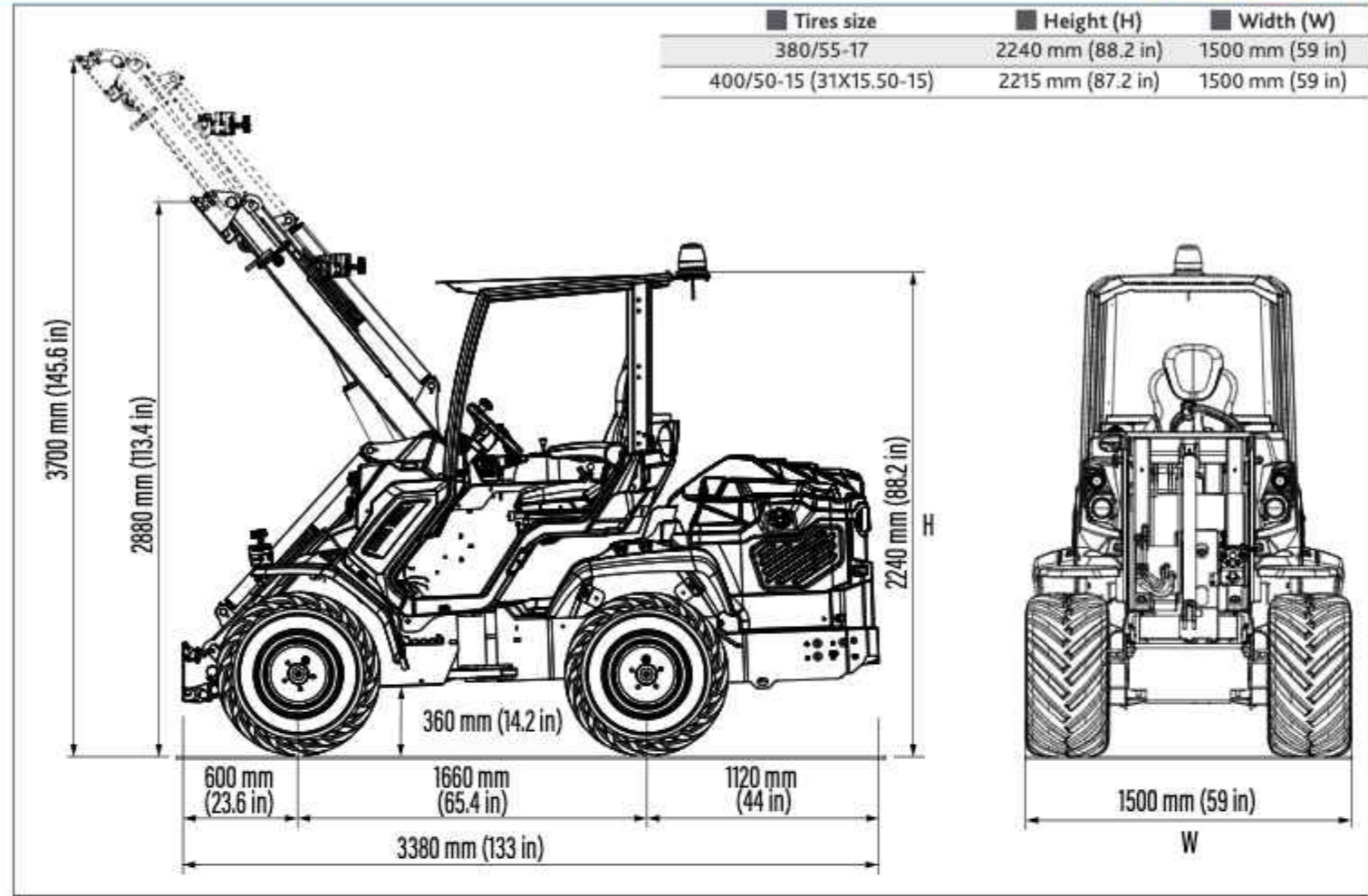

Model	11.6 K STAGE V
■ Engine	Kohler KDI 1903 - 3 cylinder - 1861 cc - Turbo common rail
■ Emission Standard	Stage V
■ Power (Iso Gross) / Torque	57 HP / 225 Nm @ 1500 rpm
■ Fuel	Diesel
■ Transmission	Hydrostatic OneDrive
■ Drive speed (max.) ⁽¹⁾	15 - 30 km/h (9.3 - 18.6 mph)
■ Aux. hydraulics oil flow	84 l/min (22.2 GPM)
■ Max. lifting height	3,7 m (145.6 in)
■ Tipping load, max. ⁽²⁾	3180 kg (7010 lbs)
■ Lifting capacity straight, max. ⁽³⁾	2540 kg (5600 lbs)
■ Breakout force / 50 cm (19.7 in)	3000 kg (6614 lbs)
■ Pushing force (c)	2650 kgf (2650 kp)
■ Average ground pressure (w/standard tires)	932 kg/m ² (192 lbs/sqft)
■ Turning radius: inside/outside	1135/2635 mm (44.7/103.7 in)
■ Standard tires (Tractor profile)	380/55-17
■ Weight	2320 kg (5115 lbs)

⁽¹⁾ Maximum speed that can be achieved with the largest diameter tires available, on a flat surface and machine without attachments.
⁽²⁾ Tipping limit, when the machine is straight, with rear weights and boom lifted just off the ground. Weight of attachment included.
⁽³⁾ Maximum load that can be lifted just off the ground when the machine is straight and with rear weights. Weight of attachment is included.
 Note: Refer to the Operator's manual for the comprehensive load diagram.

11.9 K



① PLUS

- High power and torque engine
- High speed
- High lifting height and capacity
- Multifunction Joystick + ACI
- One Drive (DBS+Cruise Control+Torque Divider)
- Self levelling telescopic boom
- High comfort:
 - Heated seat as standard
 - Smart cabin available
 - Full glass cabin available
 - Heating system available
 - A/C system available



① The biggest and strongest MultiOne.

The MultiOne 11.9 K is the new market benchmark, thanks to big equipment power and capabilities built into a compact chassis to work wherever you need.

A 75 hp, 4 cylinder, Turbo common rail engine grants outstanding performance in terms of oil flow to attachments, top speed and traction.

Moreover, the 11.9 K sets a new stand of high speed, tipping load, and lifting height. The MultiOne 11 series offers solutions that no one else can provide, with performances and capabilities far superior than those of any other loader.

It is imply the best-in-class multifunctional compact loader.

MAX LIFTING CAPACITY



2620 kg

ENGINE POWER



75 hp

SPEED



35 km/h

FLOW RATE



85 l/min

LIFT HEIGHT



3,7 m

WEIGHT



2400 kg

ACI ATTACHMENT CONTROL INTERFACE

CRUISE CONTROL



HIGHLIGHTS

- **11.9 K STAGE V** - Kohler KDI2504TCR, 75 hp, 4 cyl., 2482 cc ,Turbo common rail diesel engine with DPF, Water cooled with electric start
- Stage V compliant engine
- One Drive (DBS+Torque divider+Cruise Control) available as option
- ETC - Electronic Throttle Control
- Unbreakable Body Panels
- Hydraulic oil cooler
- Two speed
- Hydraulically pilot operated variable displacement drive pump
- Hydraulic multiconnector
- Self-levelling double-H telescopic boom
- Hi-Flow system with 2 gear pumps
- ACI with Multi-functions joystick (22 functions)
- ROPS-FOPS Level I
- LCD graphic display with programmed service
- 4WD hydrostatic Direct Drive motors, proportional servo control
- Radial piston high efficiency and heavy duty wheel motors
- 2 front working light
- Ergonomic full adjustable suspension seated heated seat with armrests and seat belt
- Self-locking multi-disk parking brake
- 380/55-17 wheels

ENGINE STAGE V

The 11.9 K model is equipped with Stage V compliant engines. The Engine is a Kohler 75 HP with DPF that provide a high torque at low rpm (300 Nm @ 1500 rpm).

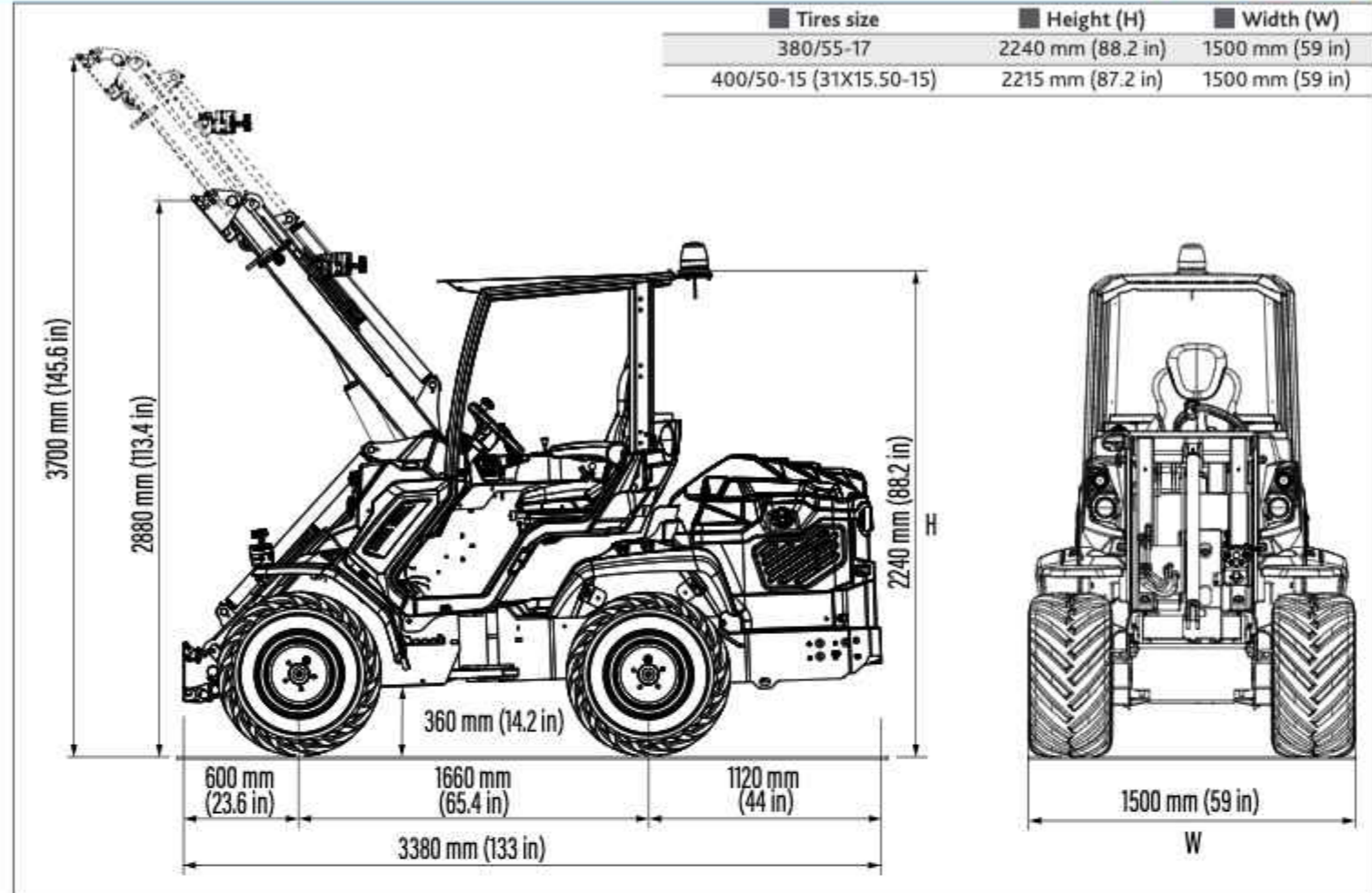

Model	11.9 K STAGE V
■ Engine	Kohler KDI 2504 - 4 cylinder - 2482 cc - Turbo common rail
■ Emission Standard	Stage V
■ Power (Iso Gross) / Torque	75 HP / 300 Nm @ 1500 rpm
■ Fuel	Diesel
■ Transmission	Hydrostatic OneDrive
■ Drive speed (max.) ⁽¹⁾	17 - 35 km/h (10.5 - 21.5 mph)
■ Aux. hydraulics oil flow	85 l/min (22,5 GPM)
■ Max. lifting height	3,7 m (145.6 in)
■ Tipping load, max. ⁽²⁾	3280 kg (7231 lbs)
■ Lifting capacity straight, max. ⁽³⁾	2620 kg (5776 lbs)
■ Breakout force / 50 cm (19.7 in)	3150 kg (6945 lbs)
■ Pushing force (c)	2650 kgf (2650 kp)
■ Average ground pressure (w/standard tires)	964 kg/m ² (197 lbs/sqft)
■ Turning radius: inside/outside	1135/2635 mm (44.7/103.7 in)
■ Standard tires (Tractor profile)	380/55-17
■ Weight	2400 kg (5291 lbs)

⁽¹⁾ Maximum speed that can be achieved with the largest diameter tires available, on a flat surface and machine without attachments.
⁽²⁾ Tipping limit, when the machine is straight, with rear weights and boom lifted just off the ground. Weight of attachment included.
⁽³⁾ Maximum load that can be lifted just off the ground when the machine is straight and with rear weights. Weight of attachment is included.
 Note: Refer to the Operator's manual for the comprehensive load diagram.

ESTATE & PROPERTY MAINTENANCE

MultiOne is the perfect tool for property maintenance, thanks to its low ground impact and ease of operation. With over 170 attachments available, you have control of the most versatile compact mini articulated loader that can be adapted for sweeping, mowing, lifting, shifting, cleaning, mixing, digging, snow clearing and much more. With compact dimensions, the articulated chassis and up front seating position grant amazing manoeuvrability in tight spaces and with all round visibility. High drive speed provides increased mobility across large areas.



LANDSCAPING & GROUND CARE

MultiOne is the most flexible compact loader for modern construction and building sites. High manoeuvrability and compact dimensions enable access to areas that conventional machinery just can't reach. The high mobility of a MultiOne helps reduce labour time, cut costs and increase productivity. MultiOne saves you time and money by reducing the number of machines needed on site, just choose your attachments, switch between them in seconds and transform your MultiOne for the next task at hand.



FARMING & NURSERY

One versatile machine, with over 170 attachments to handle bales, feed animals, clean barns & stables, prepare soil, maintain vineyards & orchards and so much more. MultiOne can handle typical farming tasks with ease, yet is compact enough to work inside buildings and barns where other machinery can't go. The compact and agile telescopic MultiOne, adds versatility and big lifting performance over and above the conventional loader.



D-I-Y & CONTRACTORS

MultiOne is the most flexible mini loader for modern construction and building sites. High manoeuvrability and compact dimensions enable access to areas that conventional machinery just can't reach. The high mobility of a MultiOne helps reduce labour time, cut costs and increase productivity. MultiOne saves you time and money by reducing the number of machines needed on site, just choose your attachments, switch between them in seconds and transform your MultiOne for the next task at hand.



ATTACHMENTS

YOU WILL BE SPOILED FOR CHOICE

MultiOne loader is designed to be used for countless tasks, thanks to its easy attachment hookups to its powerful hydraulics. And when you need to adapt to unique tasks, MultiOne manufactures a variety of tough attachments that take you well beyond bucket work.

MultiOne articulated loader attachments deliver the most versatility for your equipment investment.



COMBO BUCKET



JOB SITE TOOLBOX



RADIO CONTROLLED BACKHOE



DUMPER



LIFTING TROLLEY



RUBBER SCRAPER



TREE SHAKER



VINEYARD TOOL CARRIER



WINCH



BIG BAG LIFTER



CEMENT MIXER



COLD PLANER



CORE AERATOR



STUMP GRINDER



DEBRIS AND LEAF BLOWER



DUAL BLADE HEDGE TRIMMER



BRANCH CUTTER



INTER-ROW MOWER



JIB CRANE



LAWN MOWER



LEVELER



AERIAL WORK PLATFORM



LOG GRAPPLE



LOG SPLITTER



TRENCHER



MINI DIGGER



PALLET FORK



RIPPER



SALT AND SAND SPREADER



SNOW PLOW



TRAILER



DROP SPREADER



WEED BRUSH



TIMBER GRAB



SWEEPER



TORNADO



DEMOLITION GRAPPLE BUCKET



TREE SHEAR



CONCRETE MIXING BUCKET



DOZER BLADE



BALE FORK



HYDRAULIC BREAKER



PALLET FORK CLAMP



SWING STUMP GRINDER



FEED DISPENSER



FLAIL MOWER WITH SIDE SHIFT



GENERAL BUCKET



GRADER



HORSE ARENA HARROW



BALE HANDLER



SCREW FEED PUSHER



FLAIL MOWER



GRAPPLE BUCKET



LEAF VACUUM



MANURE FORK



ROTARY SWEEPER



POWER PLOW



SIDE BOOM WITH FLAIL MOWER



SOLAR PANEL WASHER



SPRAYER



SNOW BLOWER



HYDRAULIC BIO SHREDDER



HEDGE CUTTER



HIGH PRESSURE WASHER



PUSH BROOM



LANDSCAPE POT CLAMP



SQUARE BALE CLAMP



SCREENING BUCKET



HIGH TIP BUCKET



AUGER



SICKLE BAR MOWER



LIGHT MATERIAL BUCKET



POWER RAKE



STONE BURIER



ROTARY TILLER



SNOW BLADE



11 SERIES



① MULTIONE APP

The MultiOne App is an easy, quick and efficient way for MultiOne owners and technicians to find information they need-on the job and in the field.

MultiOne App gives an overview of the available MultiOne spare parts (for machines, attachments and options), the up-to-date user manuals and a helpful dealer locator.

① SPARE PARTS AND SERVICE

MultiOne's huge network of world wide distributors provides valuable support to the customers during the choice of the right machine and attachments to fulfill their business needs.

After the sale, the same network has deep technical training to assure the best maintenance, parts support and to help the customer discover new applications and possibilities through his MultiOne.



WWW.MULTIONE.COM

MultiOne srl

via Palù, 6/8

36040 Grumolo delle Abbadesse

Vicenza - Italy

info@multione-csf.com

The information and images herein contained are provided for illustrative purposes only and are not binding on MultiOne, who reserves the right to change them at any time without notice. 2022 MultiOne srl. All rights reserved.